

	A	B	C	D	E	F	G	H	I	J	K	L	M	N	O	P
1		Sales														
2		\$10,424														
3		+			Total Revenue											
4		Other Income	---		10448											
5		\$24														
6																
7		Cost of Goods Sold														
8		\$7,097														
9		+			--											
10		Selling & G&A														
11		\$2,718														
12		+														
13		Depreciation			Pre-Tax Expenses											
14			---		9935											
15		+														
16		Interest Expense			--											
17		\$120														
18		+														
19		Other Expenses														
20																
21																
22																
23		Cash														
24		\$179														
25		+														
26		Acct. Receivable														
27		\$718														
28		+														
29		Inventory			Current Assets											
30		\$1,127	---		2089											
31		+														
32		Other			Fixed Assets											
33		\$65			\$1,417	---										
34					+											
35					Other Assets											
36					\$1,506											
37					Accounts Payable											
38					\$770											
39					+											
40					Accrued Expenses											
41					\$905											
42					+											
43					Taxes Payable	---										
44					\$12											
45					+											
46					Other Current Expenses											
47					\$119											
48																
49																
50																
51																

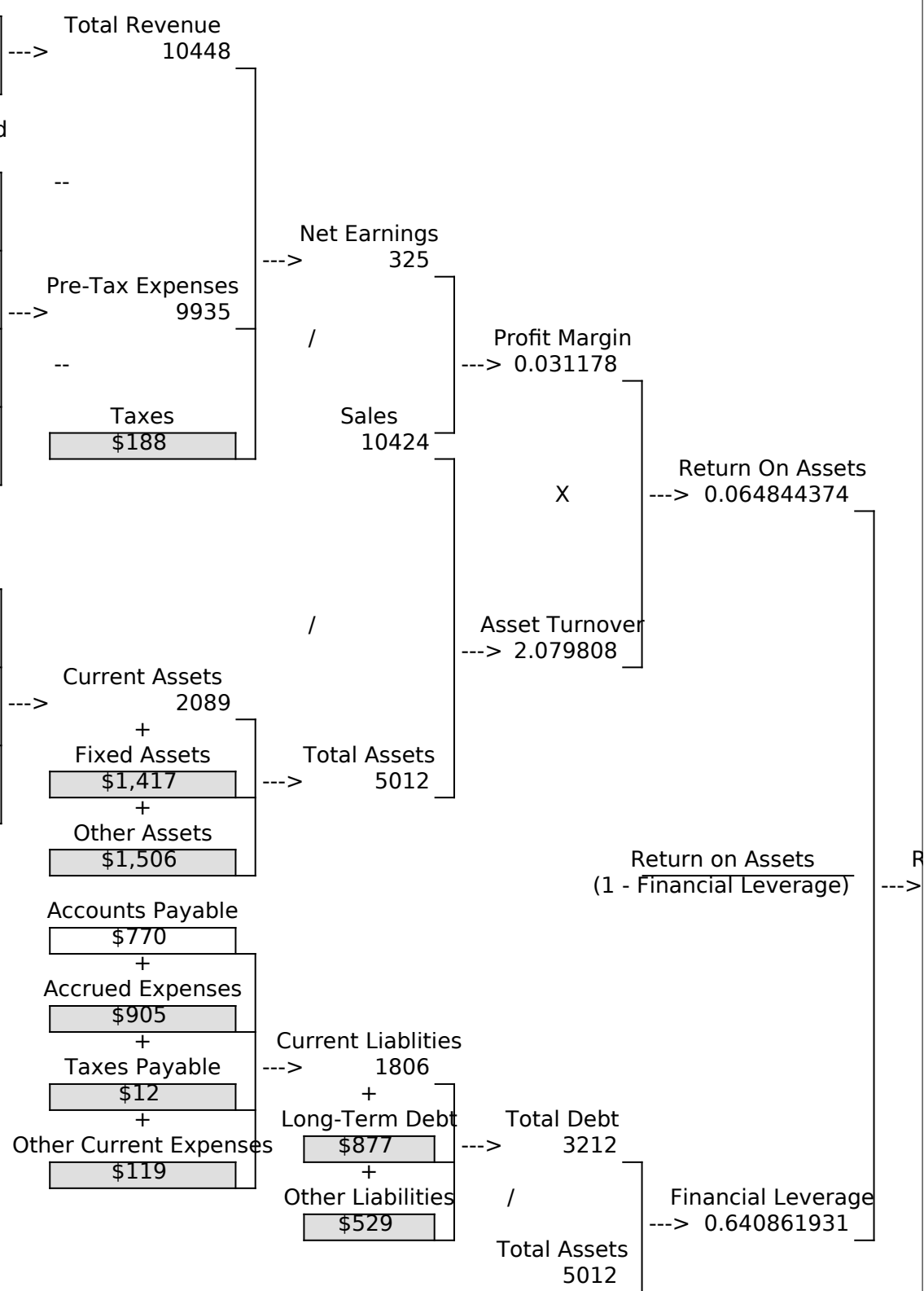

	Q	R
1		
2		
3		
4		
5		
6		
7		
8		
9		
10		
11		
12		
13		
14		
15		
16		
17		
18		
19		
20		
21		
22		
23		
24		
25		
26		
27		
28		
29		
30		
31		
32		
33		
34		
35	Return On Equity	
36	0.18055556	
37		
38		
39		
40		
41		
42		
43		
44		
45		
46		
47		
48		
49		
50		
51		